

# HSR-JR630-1800

V1.0

---





## HSR-JR630-1800 6

### HSR-JR630-1800

“ ” “ ”



.....	I
.....	III
.....	1
1 .....	3
1.1 .....	3
1.1.1 .....	3
1.1.2 .....	5
1.2 .....	8
1.3 .....	9
2 .....	10
2.1 .....	10
2.2 .....	11
2.3 .....	12
2.3.1 .....	12
2.3.2 .....	13
2.4 .....	16
2.5 .....	17
2.6 .....	18
3 .....	19
3.1 .....	19
3.1.1 .....	19
3.1.2 .....	19
3.1.3 .....	20
3.1.4 3 .....	20
3.2 .....	20
3.3 .....	21
3.4 .....	21
3.4.1 .....	21
3.4.2 .....	22
3.4.3 J1/J2/J3 .....	22
3.4.4 .....	25
3.5 .....	25
3.5.1 .....	25
3.5.2 .....	26
4 .....	28
4.1 .....	28
4.2 .....	29
4.3 .....	29

4.3.1	.....	29
4.3.2	.....	30
4.4	.....	30
4.5	.....	31
5	.....	32
5.1	.....	32
5.2	.....	32
5.3	.....	32







# 1 .

## 1.1



\_\_\_\_\_

\_\_\_\_\_



\_\_\_\_\_

\_\_\_\_\_



\_\_\_\_\_

\_\_\_\_\_

### 1.1.1

- 1 \_\_\_\_\_
- 2 \_\_\_\_\_
- 3 \_\_\_\_\_
- 4 \_\_\_\_\_ 2 1 1 \_\_\_\_\_
- 5 \_\_\_\_\_
- 6 \_\_\_\_\_ “ ”
- 7 \_\_\_\_\_



1. ....
2. ....
3. ....

“ ” “ ”

“ ” “ ”

“ ” “ ”

“ ”

1. ....
  2. ....
  3. ....
  4. ....
  5. ....
  6. ....
  7. ....
  8. ....
  9. ....
- “ ” “ ” “ ”
- ”



## 1.1.2



危险

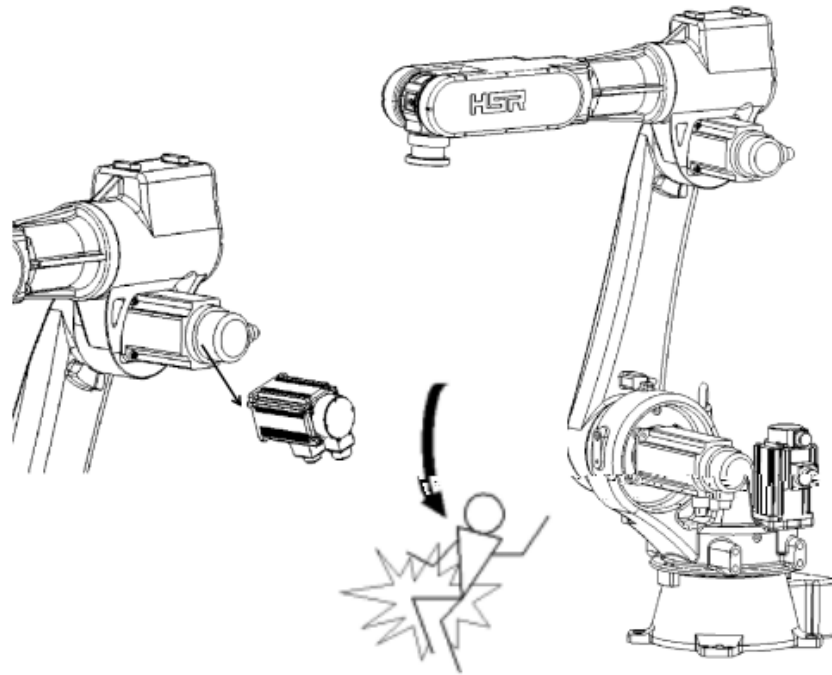



注意



注意



注意



注意



注意

Compact flash card





注意



注意



注意



注意

100%



注意

## 1.2



注意



注意

### 1.3



注意

.....



注意

.....



注意

.....



注意

.....



注意

.....

# 2

## 2.1

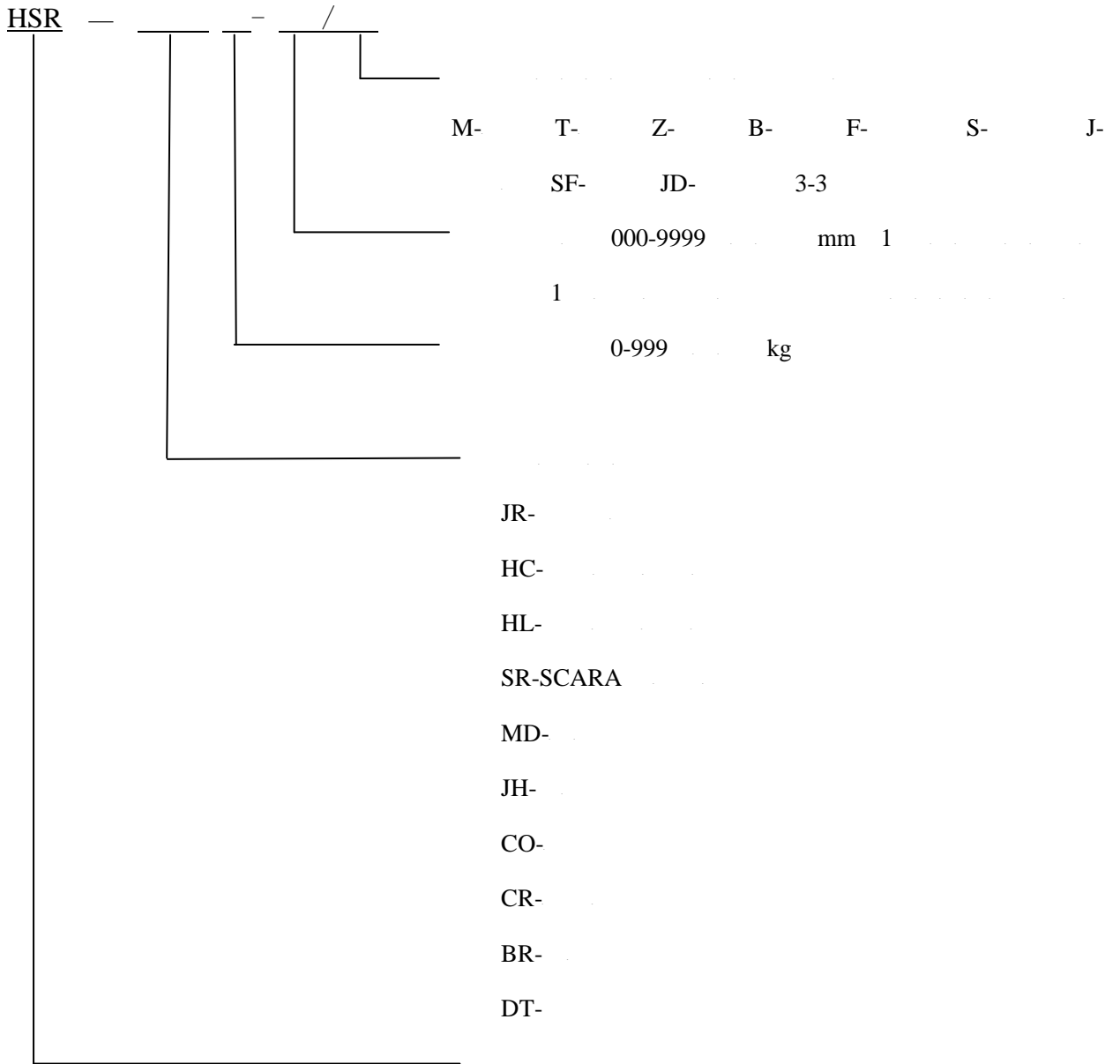



## 2.2

6

6

2.1



2.1

## 2.3

## 2.3.2

1

### 2.1 HSR-JR630-1800

		HSR-JR630-1800			
		6			
		30kg			
		1751mm			
		±0.05mm			
	J1	±155°			
	J2	-175°/+70°			
	J3	+45°/+260°			
	J4	±360°			
	J5	±125°			
	J6	±360°			
	J1	233° /s 4.06rad/s			
	J2	141° /s 2.46rad/s			
	J3	248° /s 4.32rad/s			
	J4	356° /s 6.22rad/s			
	J5	386° /s 6.74rad/s			
	J6	487° /s 8.5rad/s			
	J6	1.3 kg·m <sup>2</sup>			
	J5	3.92 kg·m <sup>2</sup>			
	J4	3.92 kg·m <sup>2</sup>			
	J6	45 N·m			
	J5	84.86 N·m			
	J4	84.86 N·m			
		0~45			
		20%-80%			
		8			
		6			
I/O		32	NPN	30	NPN
		5.62kVA			
		4.5kW			
		AC380V			
		8.1A			
		IP54			

				280kg
				IP53
	690mm	411mm	890mm	-
				91kg

2.2 HSR-JR630-1800

J1	0°	±155°
J2	-90°	-175°/+70°
J3	180°	+45°/+260°
J4	0°	±360°
J5	90°	±125°
J6	0°	±360°

2

2.2

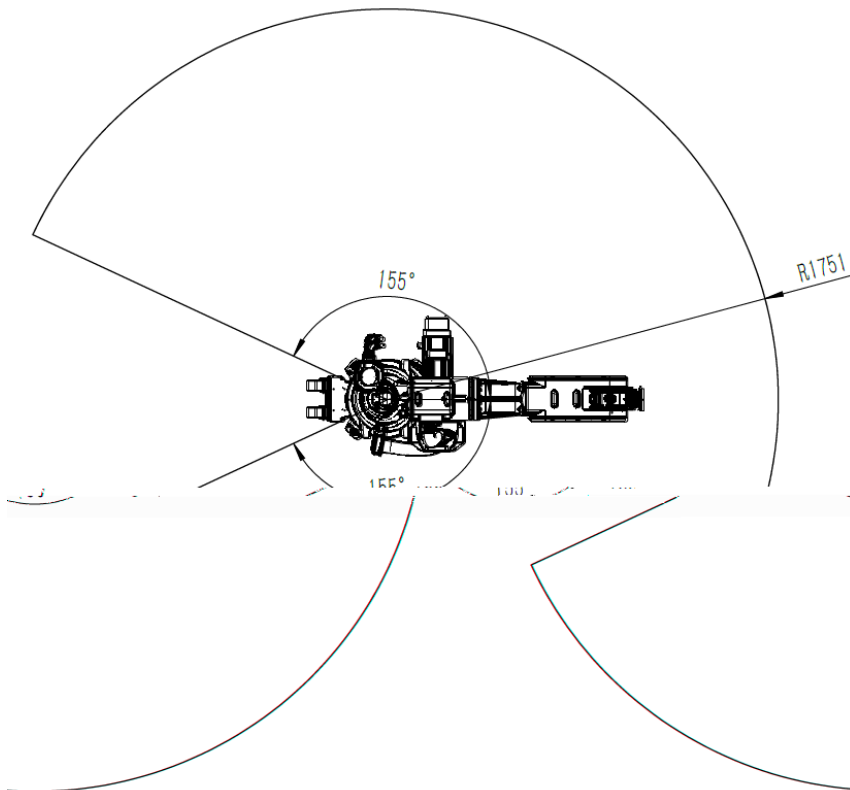

2.2 HSR-JR630-1800

## 2.4

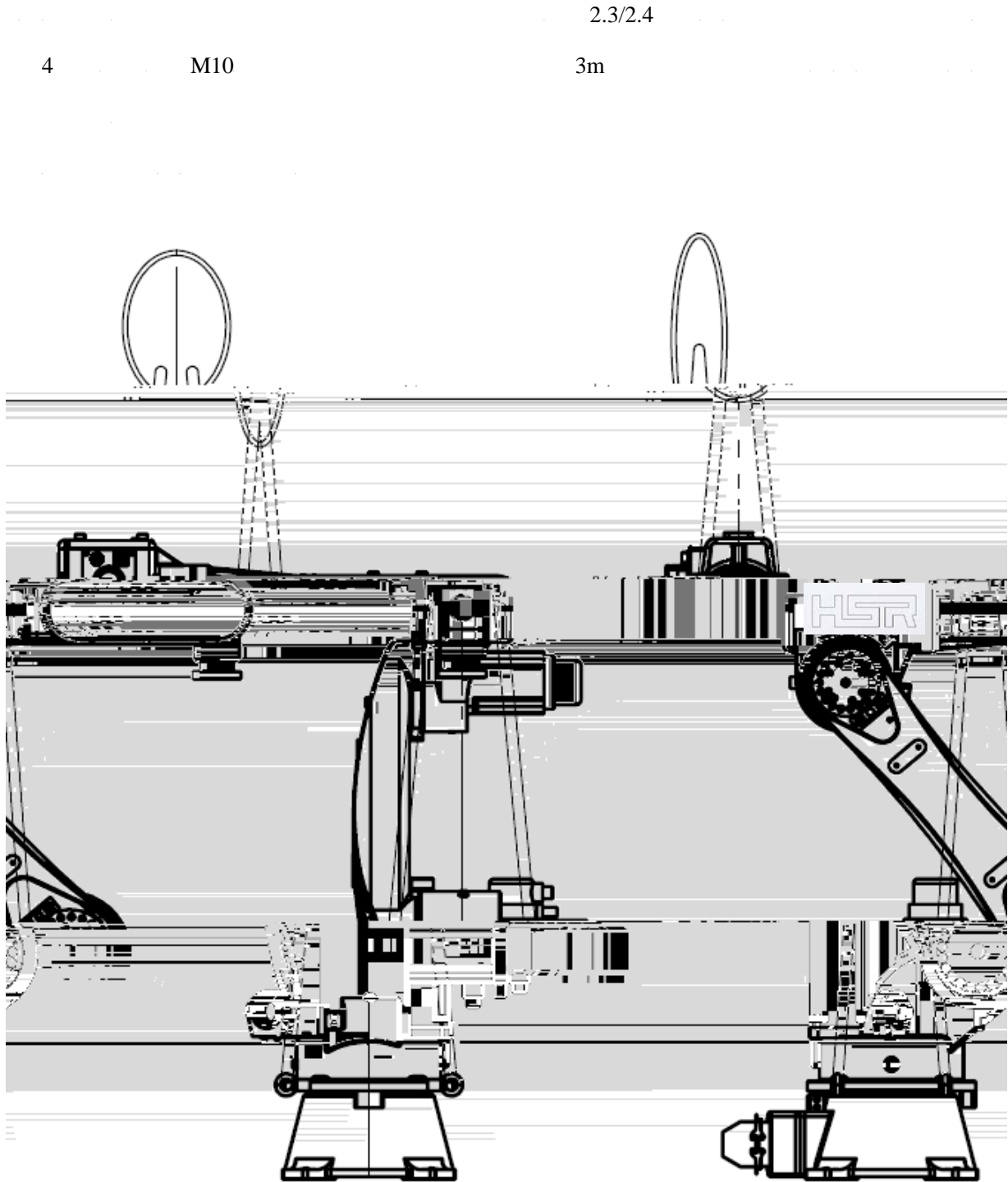

2.3/2.4

## 2.5

1)

4 M16

2.5

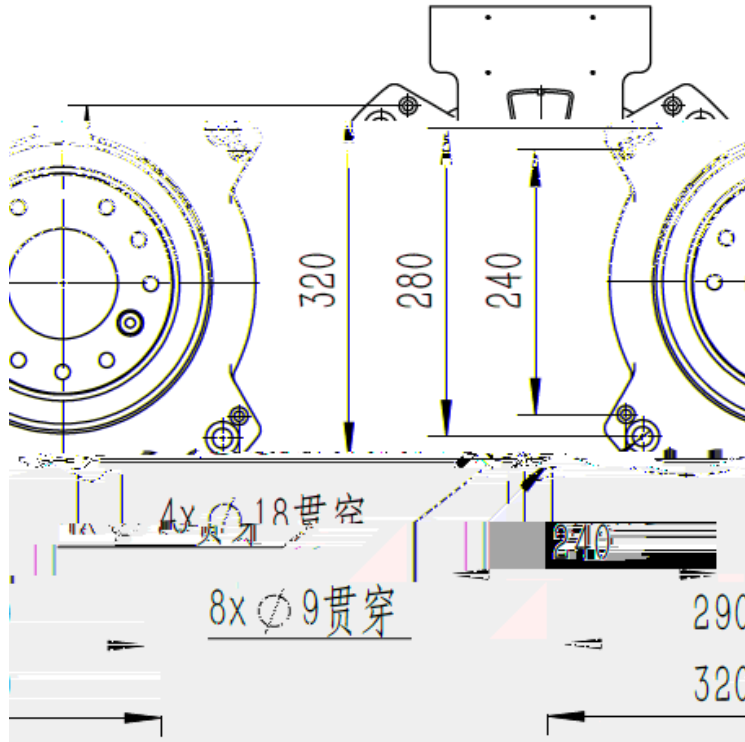

2.5

2)

2.6

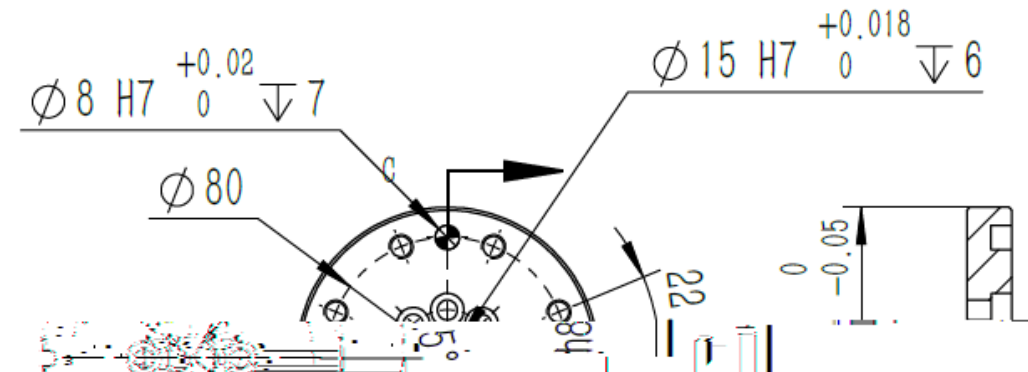

2.6

## 2.6



注意

1

### 2.3

HSR-JR630-1800	30kg

2

### 2.4

	J4	J5	J6
HSR-JR630-1800	84.8NM	84.8NM	45NM

3

### 2.5

	J4	J5	J6
HSR-JR630-1800	3.92kg.m <sup>2</sup>	3.92kg.m <sup>2</sup>	1.3kg.m <sup>2</sup>



# 3

40 000

8

### 3.1.3

3.3

1		
2		

### 3.1.4 3

3.4 3

4 5 6	

- 1 将图 3-4-3 所示的 J1、J2、J3、J4、J5 与图 3-4-2 所示的 J1、J2、J3、J4、J5 对应连接。
- 2 将图 3-4-3 所示的 J1、J2、J3、J4、J5 与图 3-4-2 所示的 J1、J2、J3、J4、J5 对应连接。

## 3.2

3.5

1		5	J4
2	J1	6	J5
3	J2	7	
4	J3	8	



**注意**

## 3.3



8

9 3.4.4

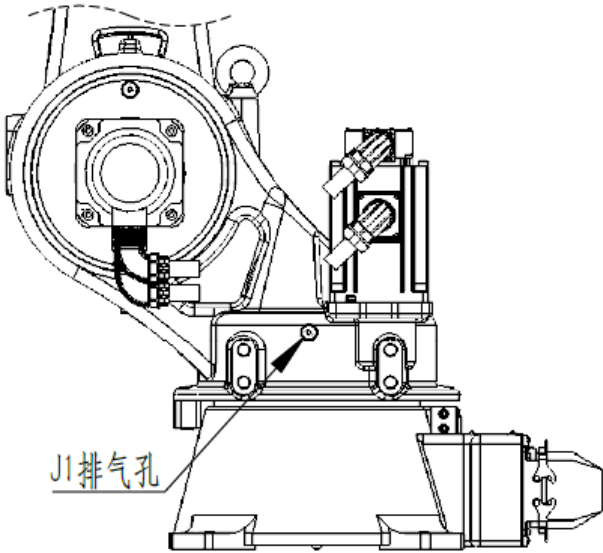

3.1

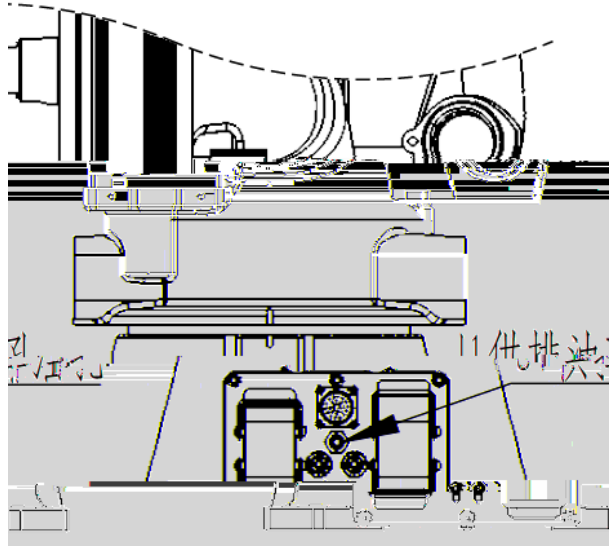

J1

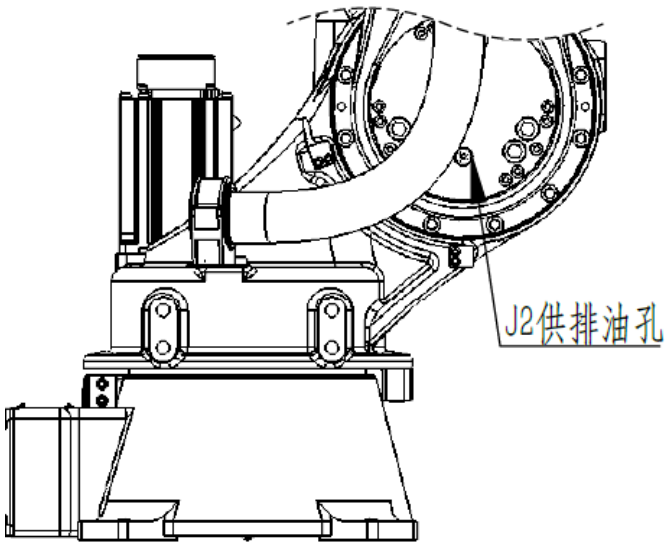

3.2

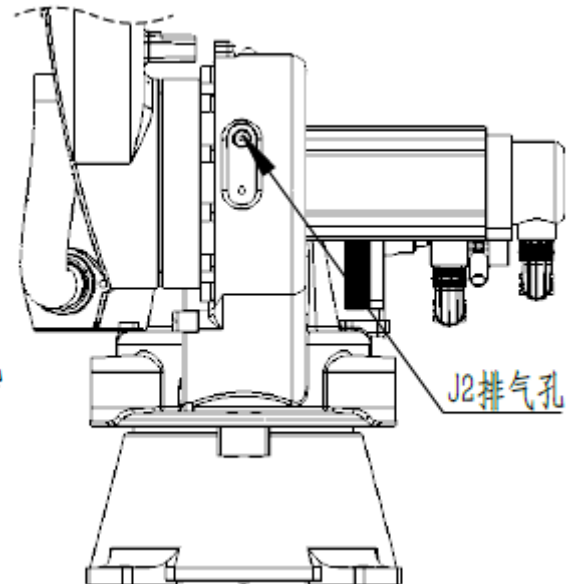

J2

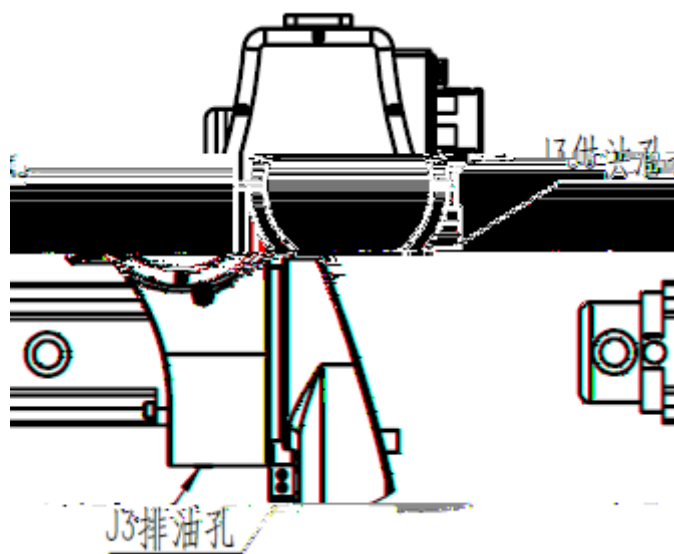

3.3 J3

### 3.4.4

.....

J1	$\pm 30^\circ$	J2/J3	$\pm 10^\circ$	20
----	----------------	-------	----------------	----

.....

## 3.5

### 3.5.1

.....

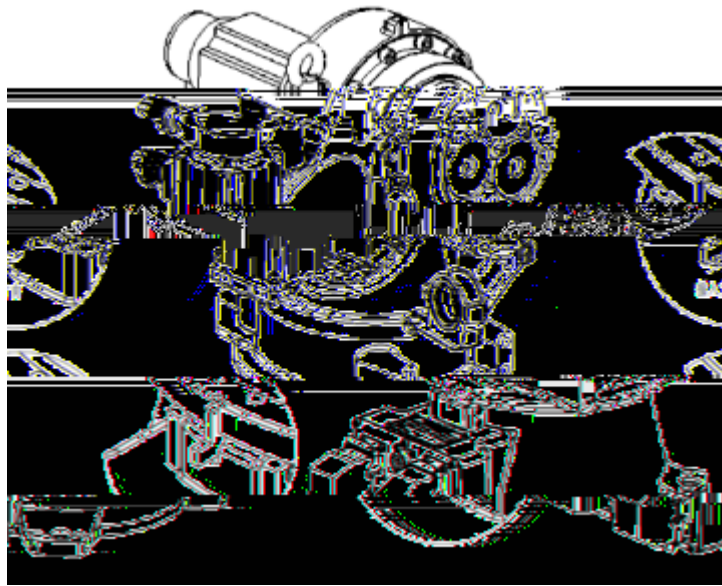

3.4

3.4

U

U



注意

### 3.5.2

3.5-3.8

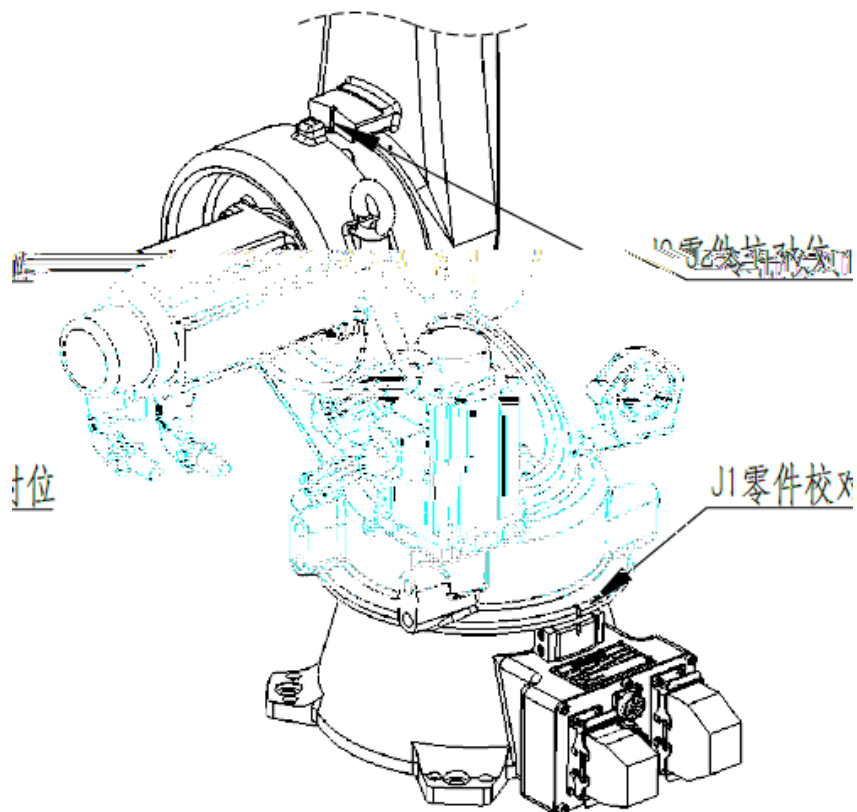

3.5 J1/J2

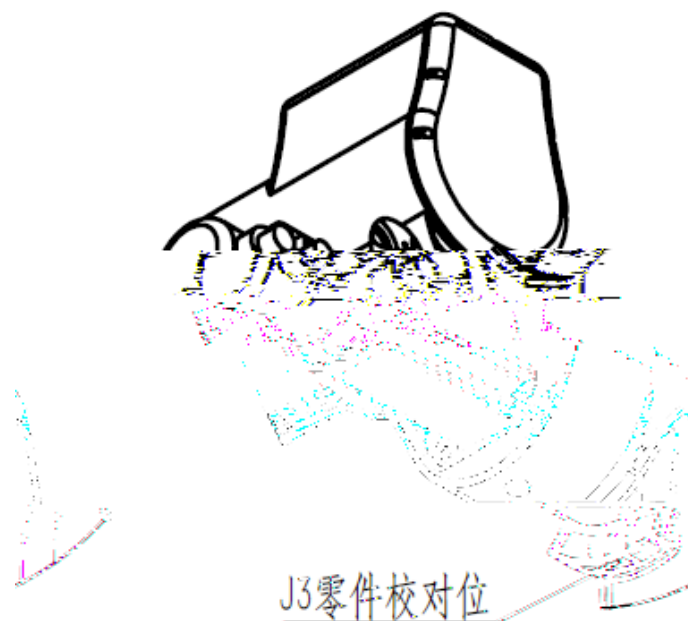

3.6 J3





3.7 J4 零件装配

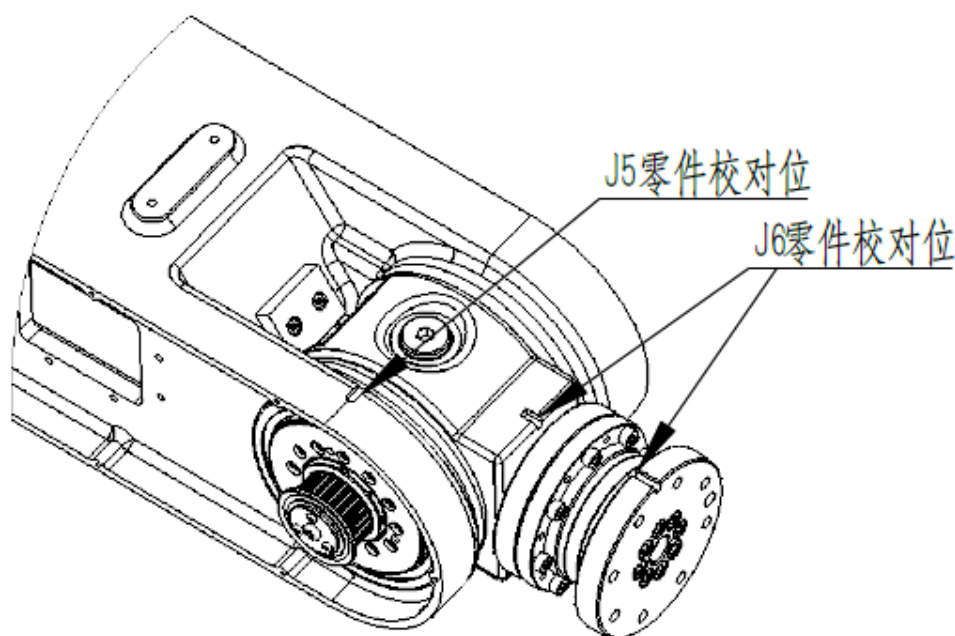

3.8 J5 J6 零件装配

# 4

## 4.1

- 1
- 2
- 3
- 4
- 5
- 6

OFF

(2) (3) (4)

### 1.

### 2.

### 3.

4.3

## 4.2

### 4.1

#### 4.1

[ 1 ]		
[ 2 ]		
[ 3 ]		

[ 1 ]

[ 2 ]

[ 3 ]

## 4.3

### 4.3.1

1

1000ppm

5,000

1

2,500

10°

2

### 4.3.2

1

2

## 4.4

1)

2)

3)

4)

5)

6)

### 4.5

4.1 4.2

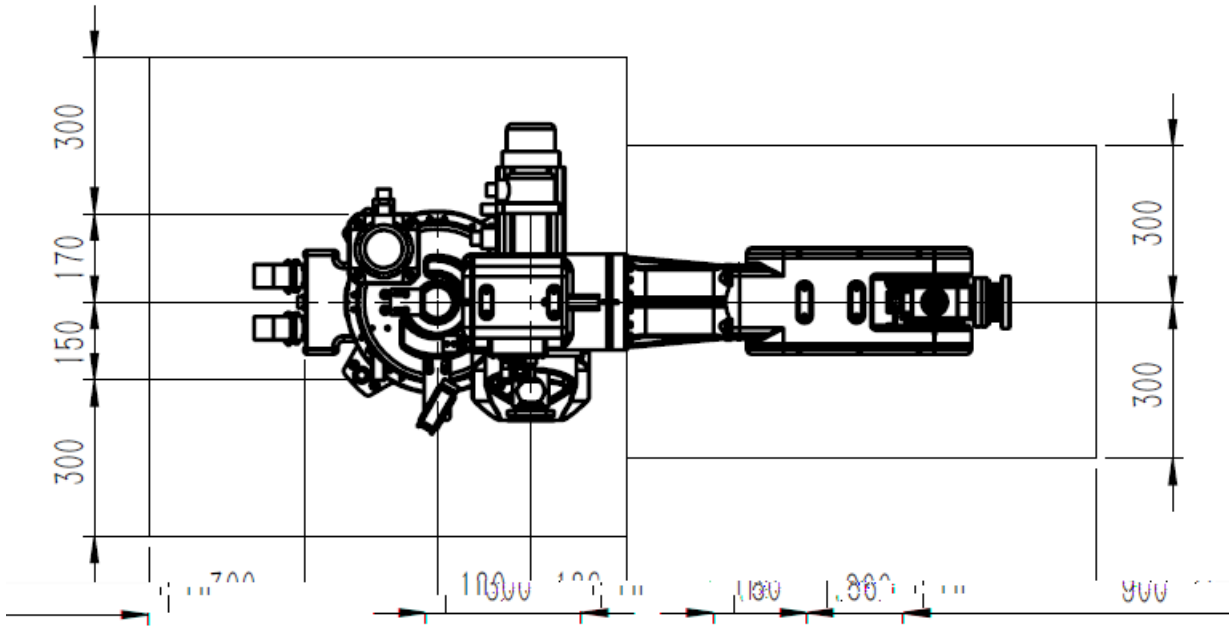

4.1 HSR-JR630-1800

# 5

## 5.1

A	3.5
B	3.5

## 5.2

	S5M-390-15	3.1.3
	S5M-475-15	3.1.3
	S5M-690-15	3.1.3

## 5.3

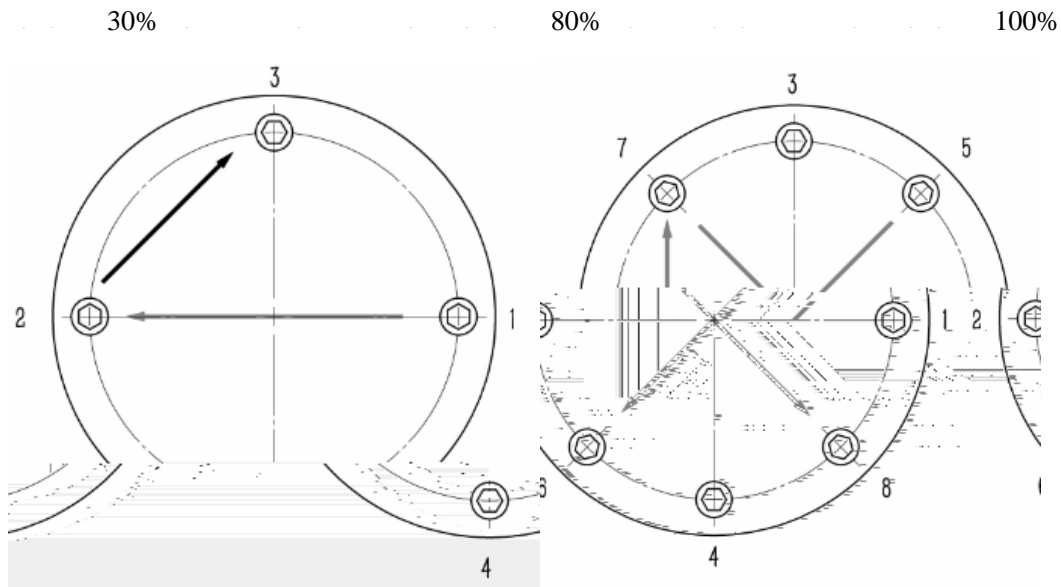

- 1
- 2
- 3

2

4

5

5-1

	8.8		12.9	
	Nm	Nm	Nm	Nm
M3	1.2	1.1 1.5	2	1.6 2.2
M4	2.5	2.2 3.5	4.8	3.8 5.7
M5	5	3.2 4.4	9.3	8.4 10.2
M6	8	7.4 11.2	16	15 18
M8	20	16 26	42	35 53
M10	40	36 52	80	74 88
M12	75	61 94	129	120 138
M14	120	97 150	205	195 220
M16	200	170 230	380	320 425

8.8

.....

.....

.....

.....

.....

.....

.....

.....

.....

1

2

3



.....

.....



5 69

400714

**023-88026878**

service\_cq@hzncc.com

19

528234

**0757-81991717**

service\_fs@hzncc.com





官方网站: [www.huasrobotics.com](http://www.huasrobotics.com)

服务热线: 4008855299



www.huasrobotics.com



